

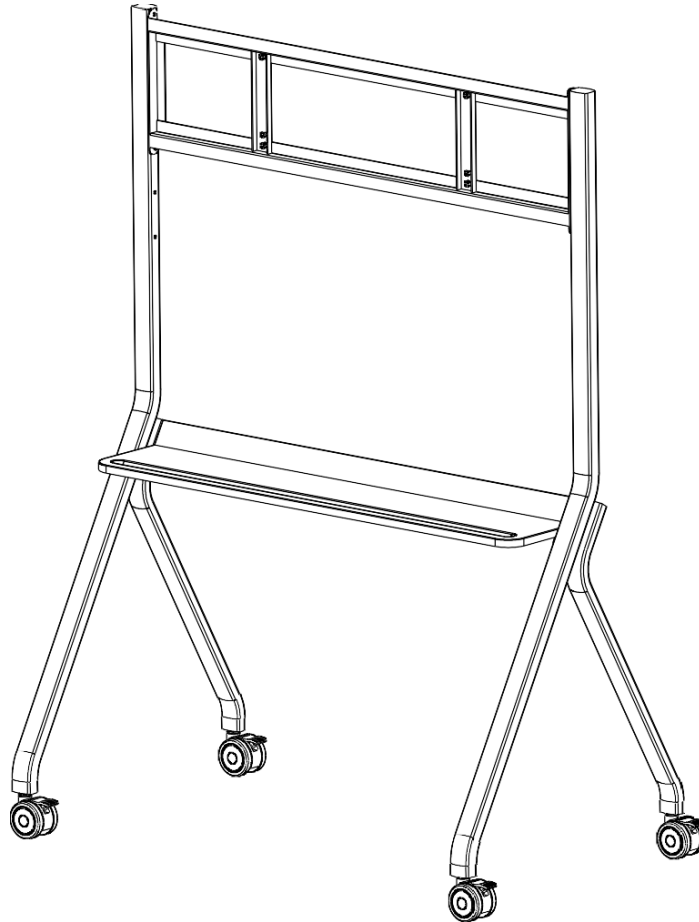

DISPLAYS2GO

ASSEMBLY INSTRUCTIONS



-
- To ensure your personal safety and proper use of the product, please read this manual carefully before installation.
 - This product is compatible with 65-86 inch smart interactive displays.
 - This product can bear up to 220 lbs.

● Packing List:

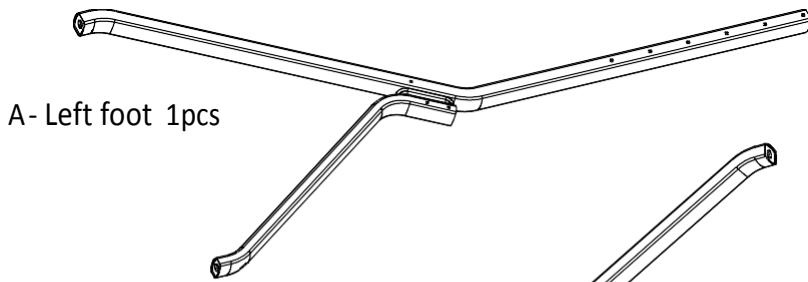

A- Left foot 1pcs

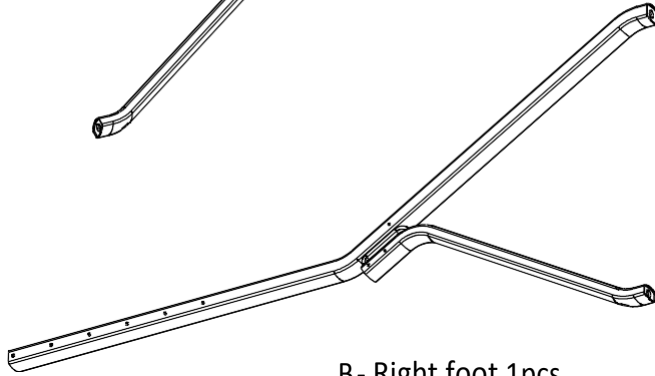

B- Right foot 1pcs



D - Shelf 1pcs

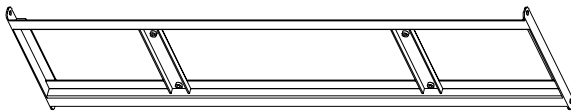





C - Bracket 1pcs



E - Caster 4pcs

Hardware and Tools:

Cross recessed hex head screw (including positioning bolts)	M8×25	14pcs	
M12 spring washer		4pcs	
Phillips screwdriver (user-supplied)		1pcs	
Adjustable wrench (user-supplied)		1pc	

Step 1: Lock the casters in place to prevent movement during assembly, and then screw the casters to the bottom of the feet (see Figure 1).

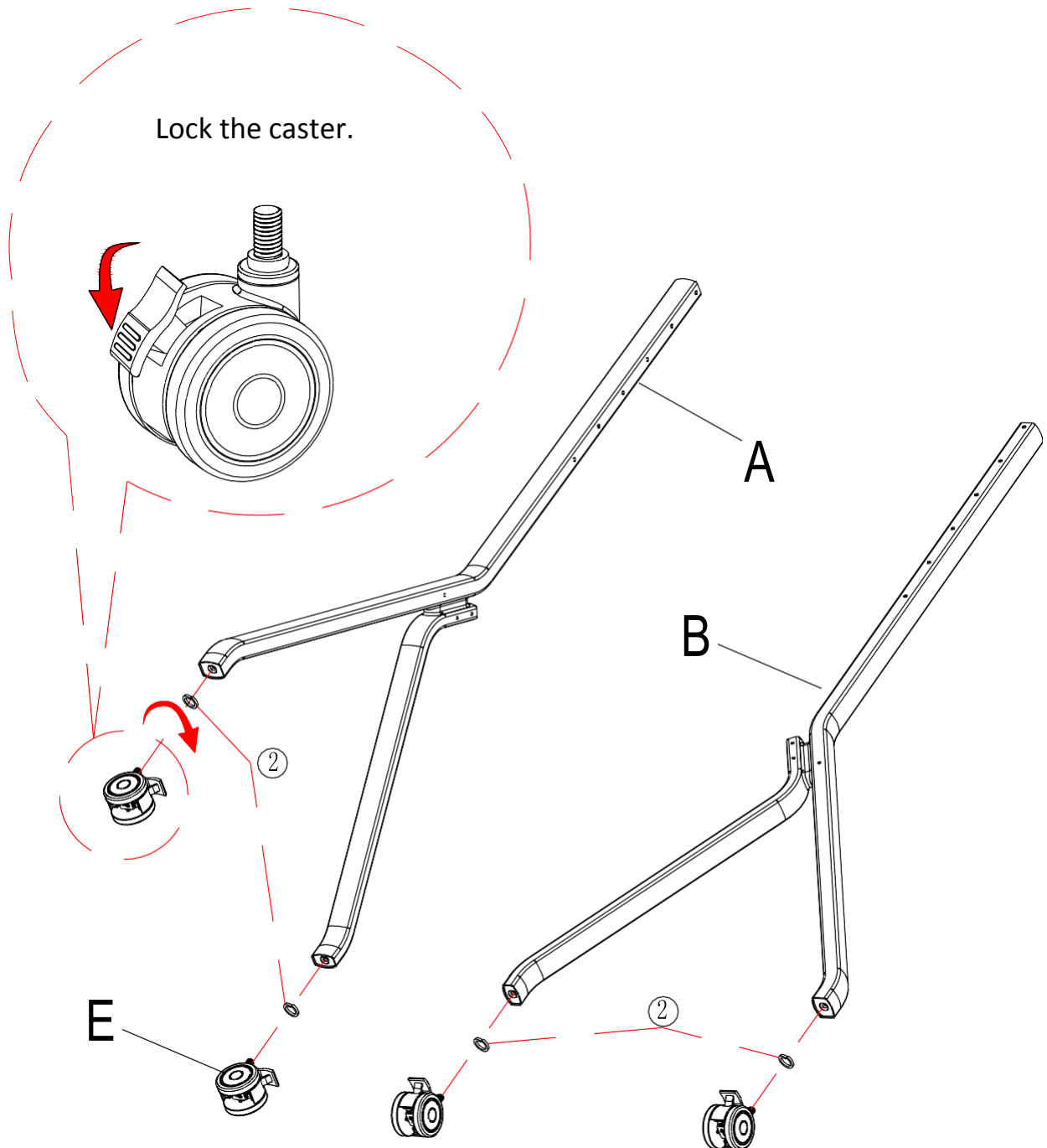

Figure 1

Step 2: Attach the bracket to one foot (see Figure 2).

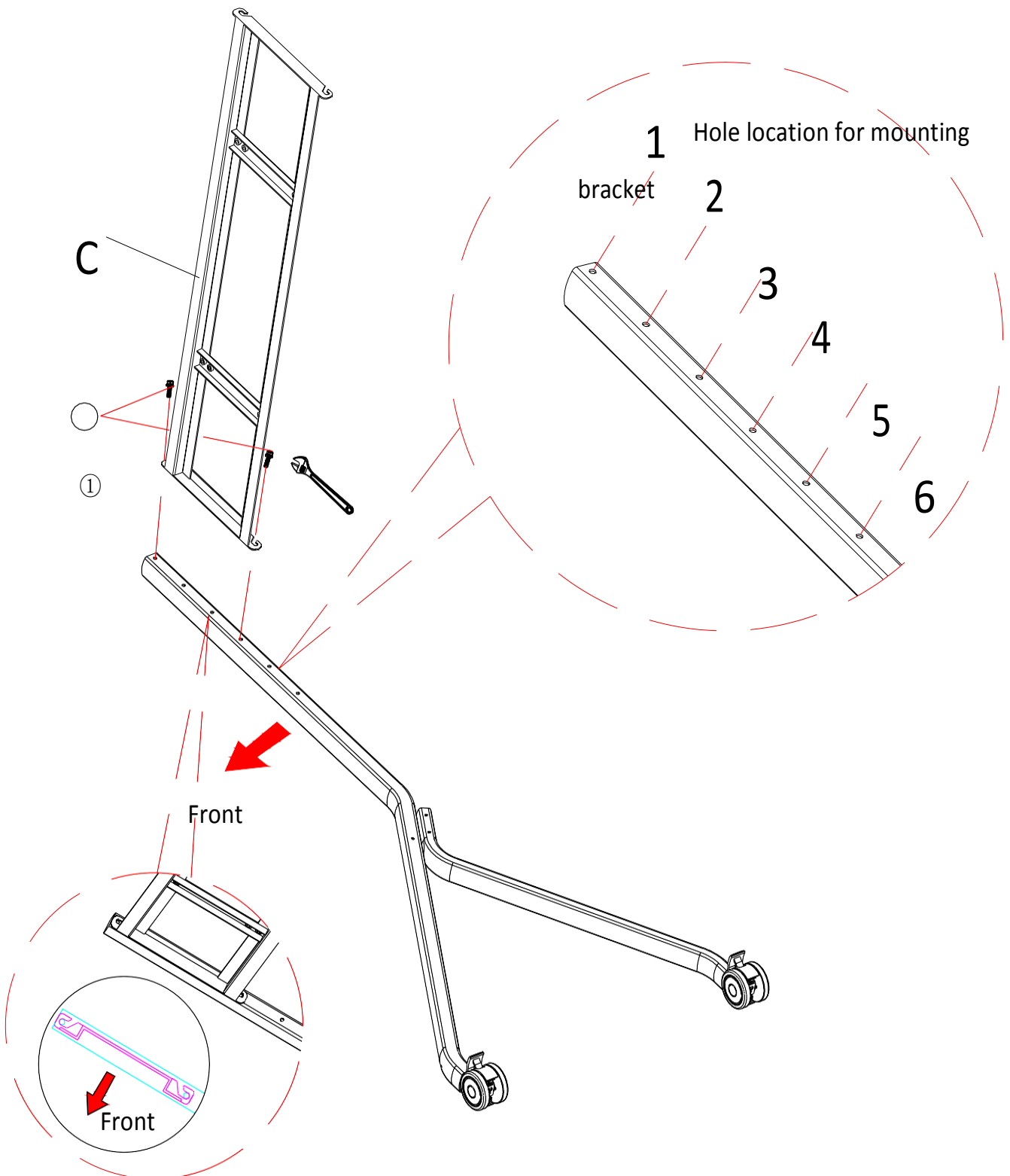

Figure 2

Step 3: Attach the other foot to the bracket (see Figure 3).

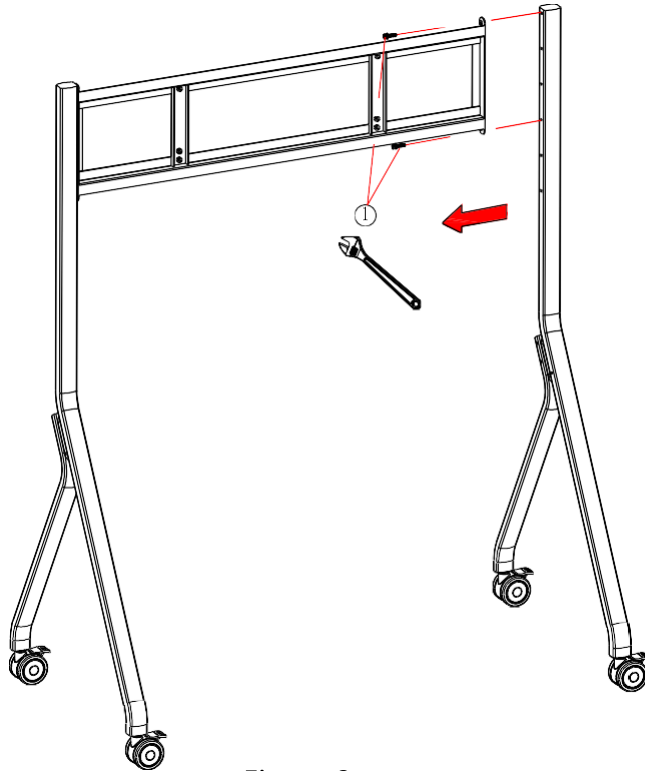

Figure 3

Step 4: Install the shelf (see Figure 4).

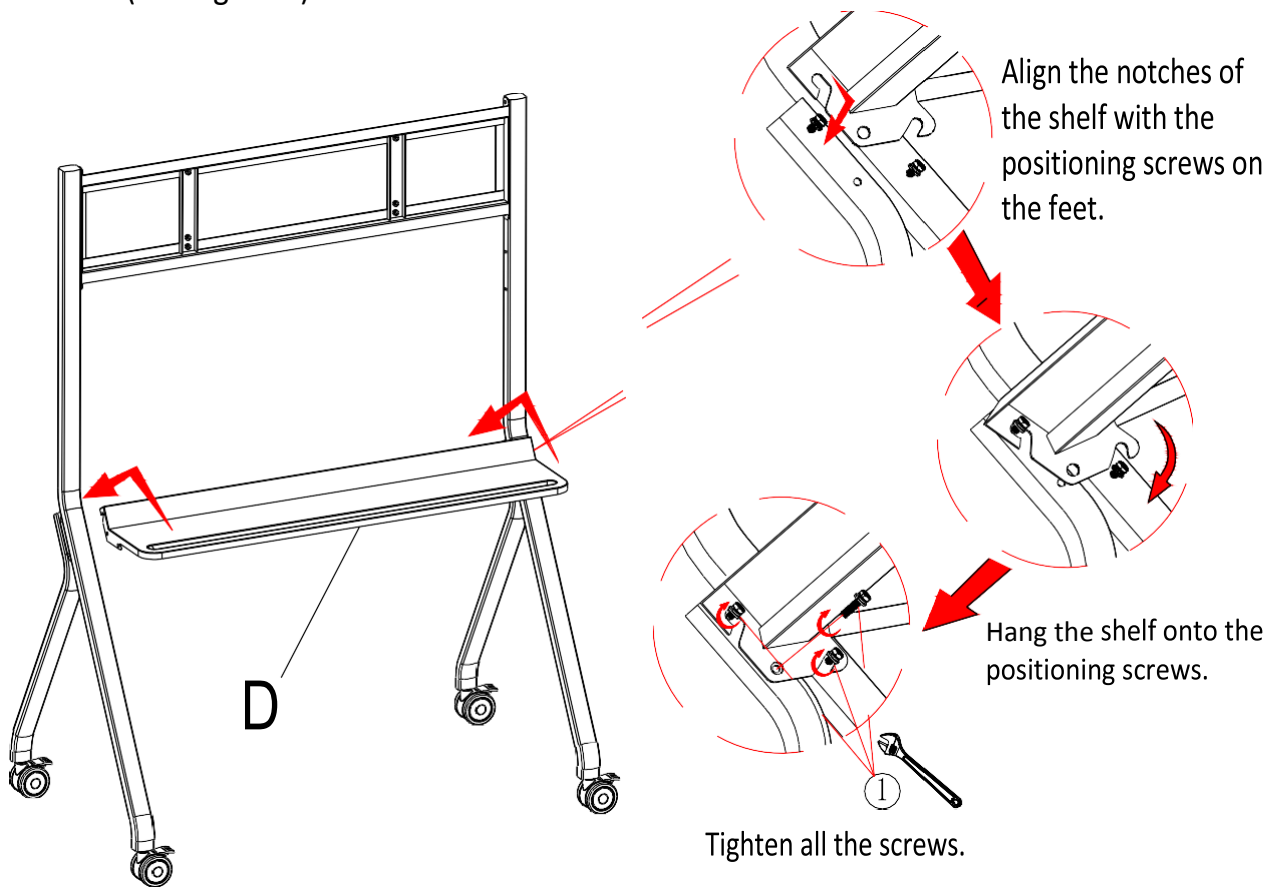

Figure 4

Step 5: Attach the two hooks to the back of the display (see Figure 5).

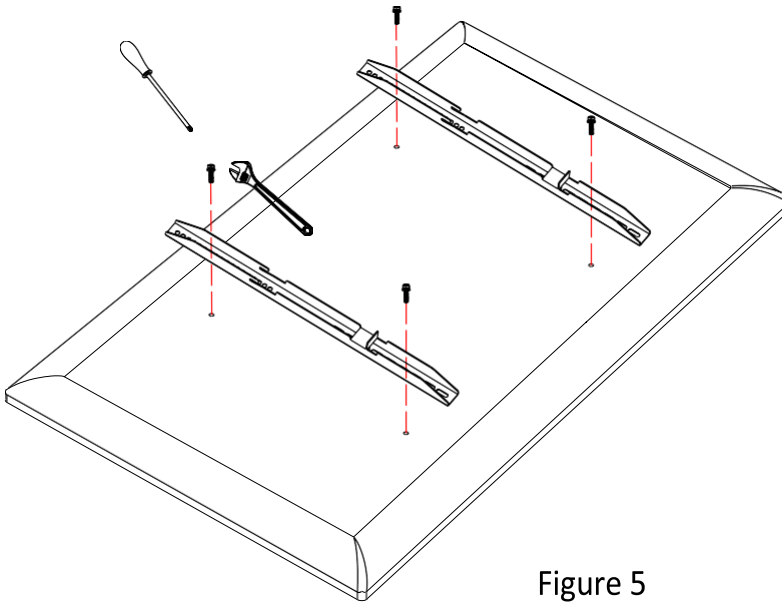

Figure 5

Step 6: Hang the hooks with display onto the bracket and tighten the security bolts on the bottom of the hooks (see Figure 6).

⚠ Ensure the casters are locked in place. This operation shall be completed by at least two professionals.

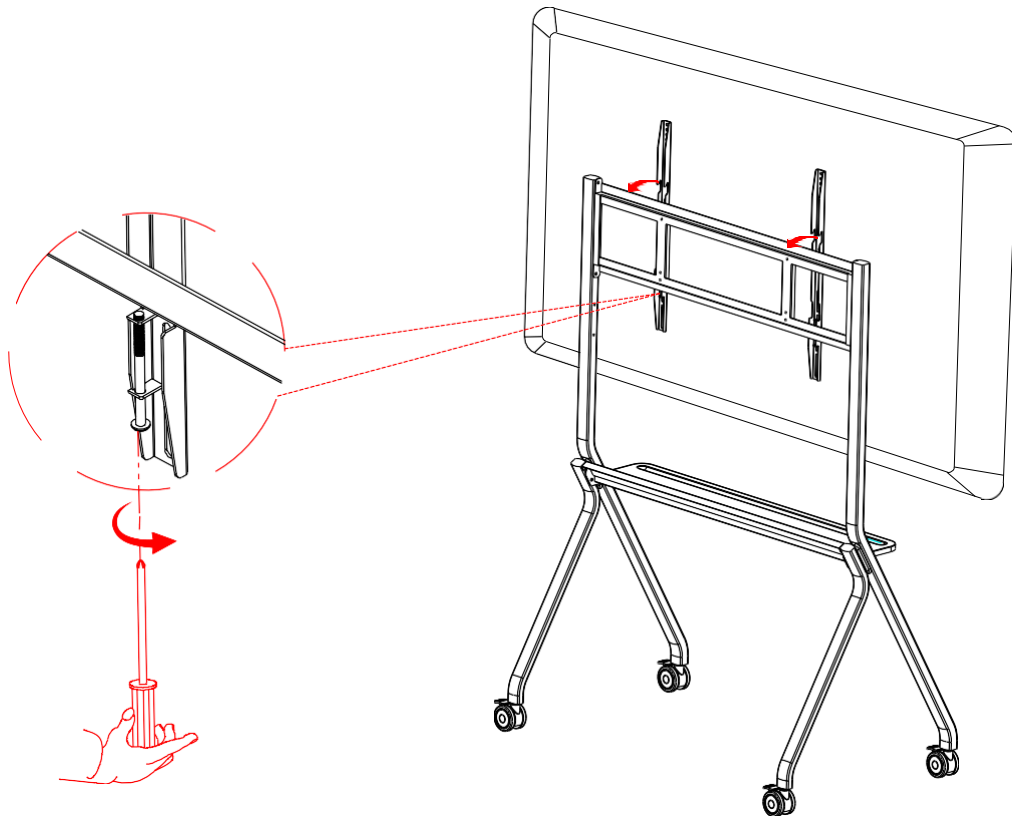
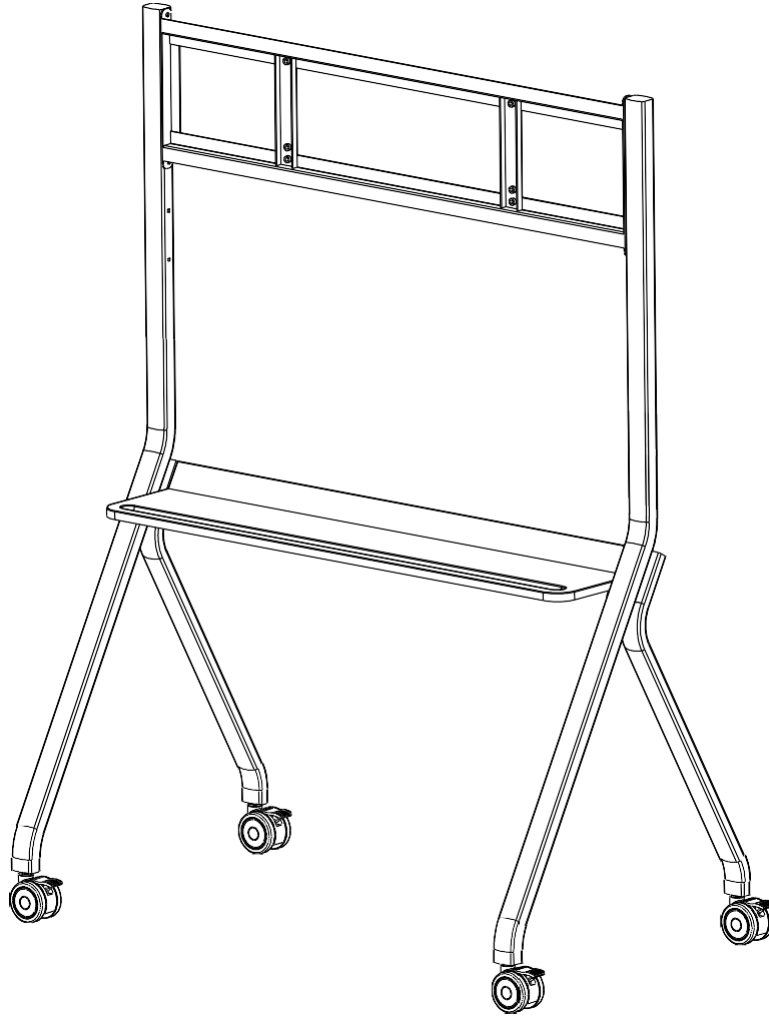

Figure 6

Step 7: Refer to the figure below to check if the product is installed properly.



If you have any questions regarding our products, please visit us at www.displays2go.com or contact our customer service at 1-844-221-3393.